

ALL MEASUREMENTS IN THE SPACE SHOULD BE TAKEN FROM THE INTERIOR OF THE HATCH NOT THE DASHED LINE

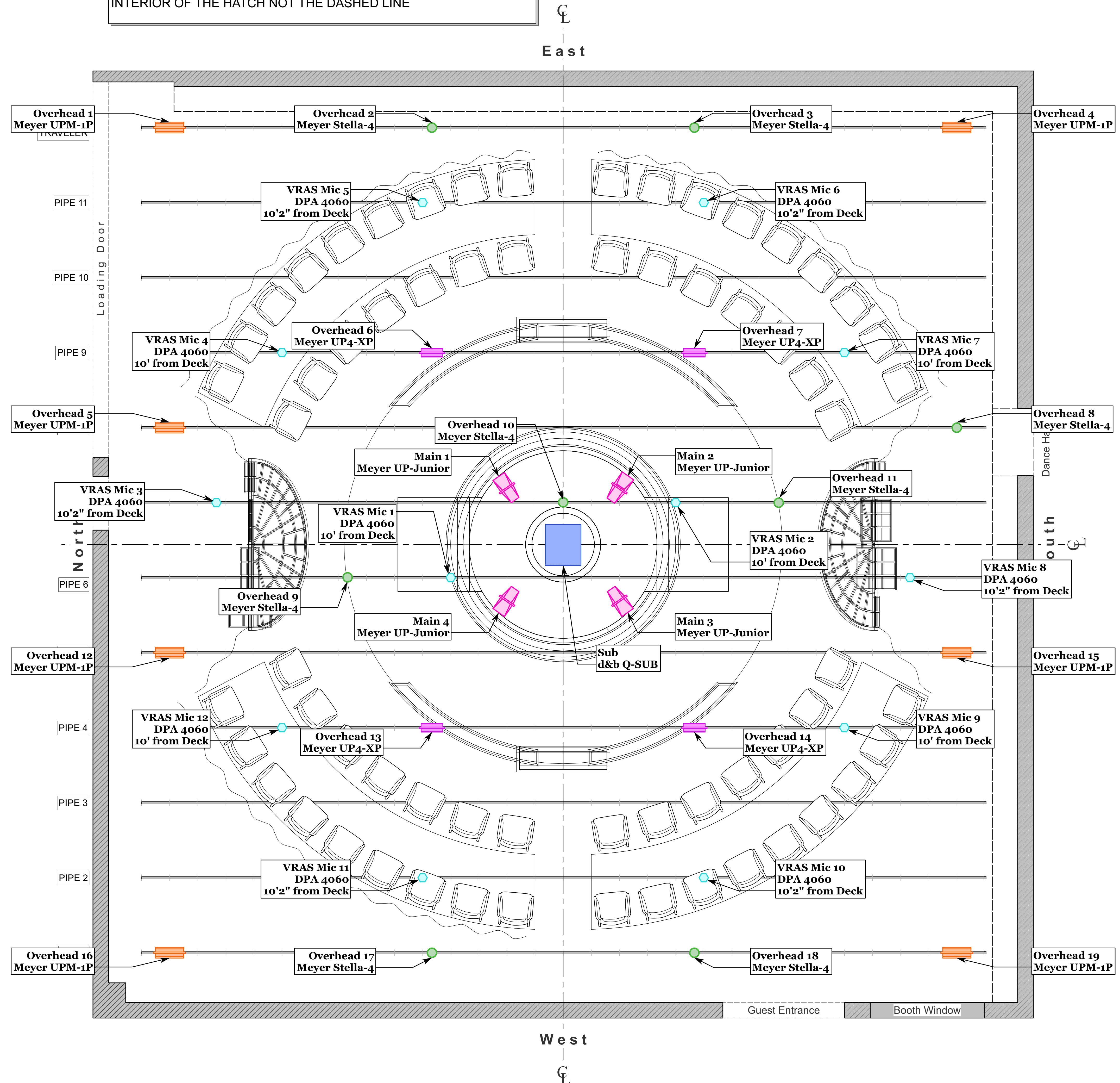

SOUND DESIGN BY:

COSTANDINA J. DAROS

NOTES:

1)

**FINALS**

THIS DRAFTING REPRESENTS CONCEPTS AND CONSTRUCTION SUGGESTIONS ONLY

THE DESIGNER IS UNQUALIFIED TO DETERMINE THE STRUCTURAL OR ELECTRICAL APPROPRIATENESS OF THIS DESIGN AND ASSUMES NO RESPONSIBILITY FOR IMPROPER ENGINEERING, CONSTRUCTION, RIGGING, HANDLING, OR USE. FINISHED SYSTEM MUST COMPLY WITH ALL STATE AND LOCAL CODES.



**ROBERT COHEN THEATRE**

**THE EFFECT**

**DIRECTOR**  
CHLOE KING

**STAGE MANAGER**  
BRI WESTAD

**SCENIC DESIGNER:**  
JACQUELYNE EDWARDS

**COSTUME DESIGNER:**  
DENISE LARSSON

**LIGHTING DESIGNER:**  
NITA MENDOZA

**ASST. SOUND DESIGNER:**  
AERIK HARBERT

**SOUND SUPERVISOR:**  
JEFF POLUNAS

**SUBMITTALS:**

#	DATE:	DESCRIPTION:
1	02.12.2022	PRELIMINARY SUBMITTAL
2	02.27.2022	INTERMEDIATE
3	03.12.2022	FINALS
4		

**GROUNDPLAN**

SCALE: 3/8" = 1'-0"  
DRAWN BY: C. DAROS  
PLATE: 1 OF 7



SOUND DESIGN BY:

COSTANDINA J. DAROS

NOTES:

1) VRAS MIC 1 AND 3 COVERED IN THIS VIEW. FIND THEIR INFO IN N/S SECTION

FINALS

THIS DRAFTING REPRESENTS CONCEPTS AND CONSTRUCTION SUGGESTIONS ONLY

THE DESIGNER IS UNQUALIFIED TO DETERMINE THE STRUCTURAL OR ELECTRICAL APPROPRIATENESS OF THIS DESIGN AND ASSUMES NO RESPONSIBILITY FOR IMPROPER ENGINEERING, CONSTRUCTION, RIGGING, HANDLING, OR USE. FINISHED SYSTEM MUST COMPLY WITH ALL STATE AND LOCAL CODES.



ROBERT COHEN THEATRE

THE EFFECT

DIRECTOR  
CHLOE KING

STAGE MANAGER  
BRI WESTAD

SCENIC DESIGNER:  
JACQUELYNE EDWARDS

COSTUME DESIGNER:  
DENISE LARSSON

LIGHTING DESIGNER:  
NITA MENDOZA

ASST. SOUND DESIGNER:  
AERIK HARBERT

SOUND SUPERVISOR:  
JEFF POLUNAS

SUBMITTALS:

#	DATE:	DESCRIPTION:
1	02.12.2022	PRELIMINARY SUBMITTAL
2	02.27.2022	INTERMEDIATE
3	03.12.2022	FINALS
4		

SECTION W/E

SCALE: 1/2" = 1'-0" PLATE:  
DRAWN BY: C. DAROS 2 OF 7

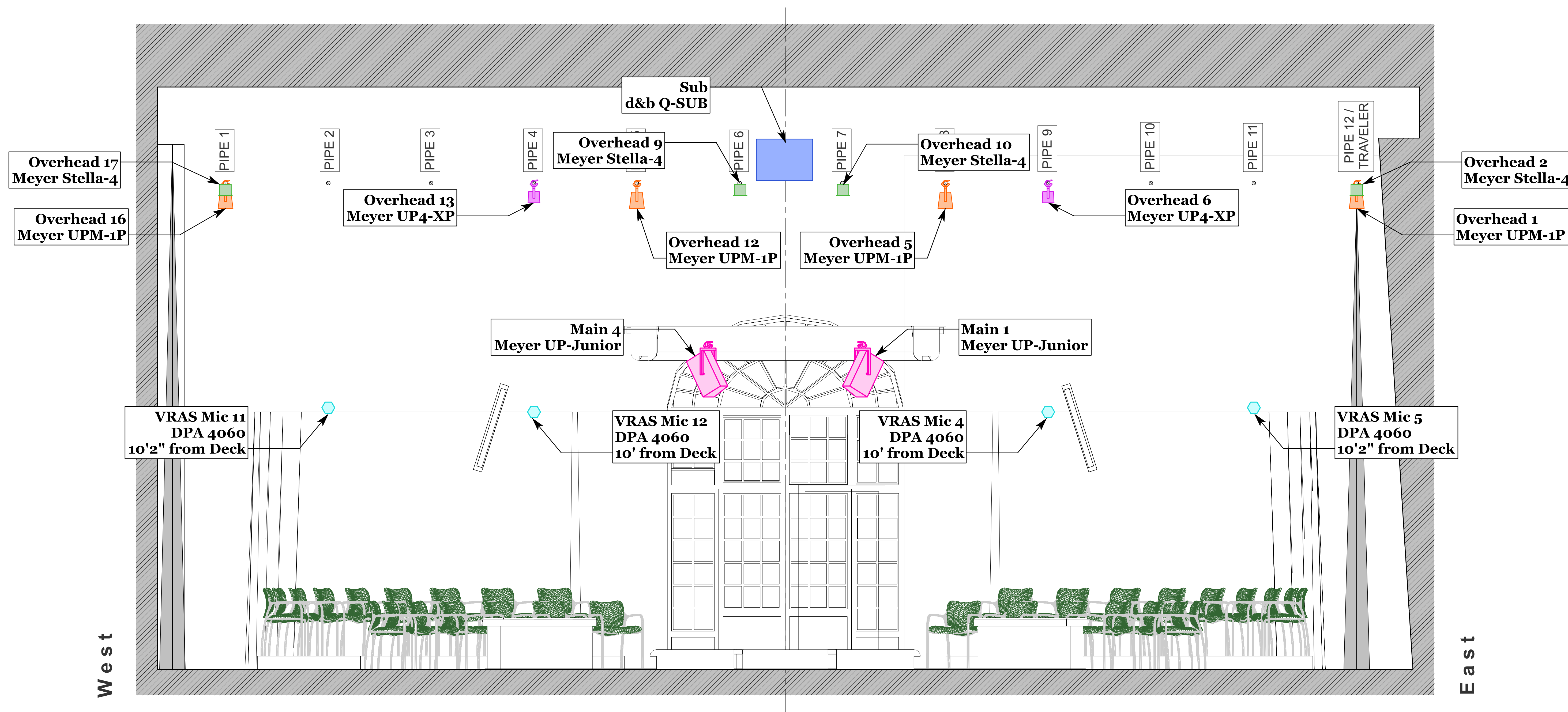

West

East



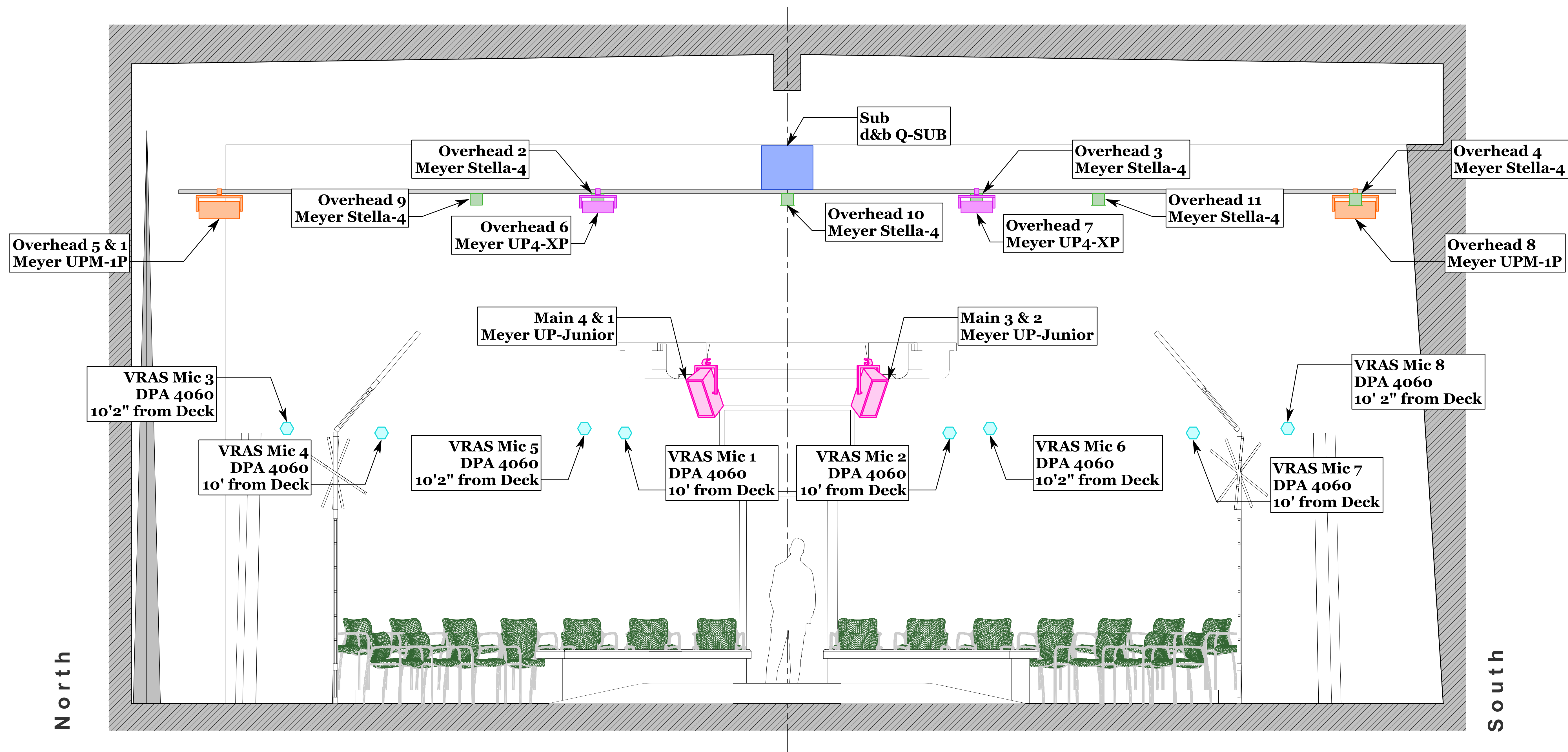

SOUND DESIGN BY:

COSTANDINA J. DAROS

NOTES:

1) SECTION CUT IS SLIGHTLY OFF-CENTER TO SHOW MORE OF THE MICROPHONES FOR CLARITY

**FINALS**

THIS DRAFTING REPRESENTS CONCEPTS AND CONSTRUCTION SUGGESTIONS ONLY

THE DESIGNER IS UNQUALIFIED TO DETERMINE THE STRUCTURAL OR ELECTRICAL APPROPRIATENESS OF THIS DESIGN AND ASSUMES NO RESPONSIBILITY FOR IMPROPER ENGINEERING, CONSTRUCTION, RIGGING, HANDLING, OR USE. FINISHED SYSTEM MUST COMPLY WITH ALL STATE AND LOCAL CODES.



**ROBERT COHEN THEATRE**

**THE EFFECT**

**DIRECTOR**  
CHLOE KING

**STAGE MANAGER**  
BRI WESTAD

**SCENIC DESIGNER:**  
JACQUELYNE EDWARDS

**COSTUME DESIGNER:**  
DENISE LARSSON

**LIGHTING DESIGNER:**  
NITA MENDOZA

**ASST. SOUND DESIGNER:**  
AERIK HARBERT

**SOUND SUPERVISOR:**  
JEFF POLUNAS

**SUBMITTALS:**

#	DATE:	DESCRIPTION:
1	02.12.2022	PRELIMINARY SUBMITTAL
2	02.27.2022	INTERMEDIATE
3	03.12.2022	FINALS
4		

**SECTION N/S**

SCALE: 1/2" = 1'-0"  
DRAWN BY: C. DAROS

PLATE: 3 OF 7



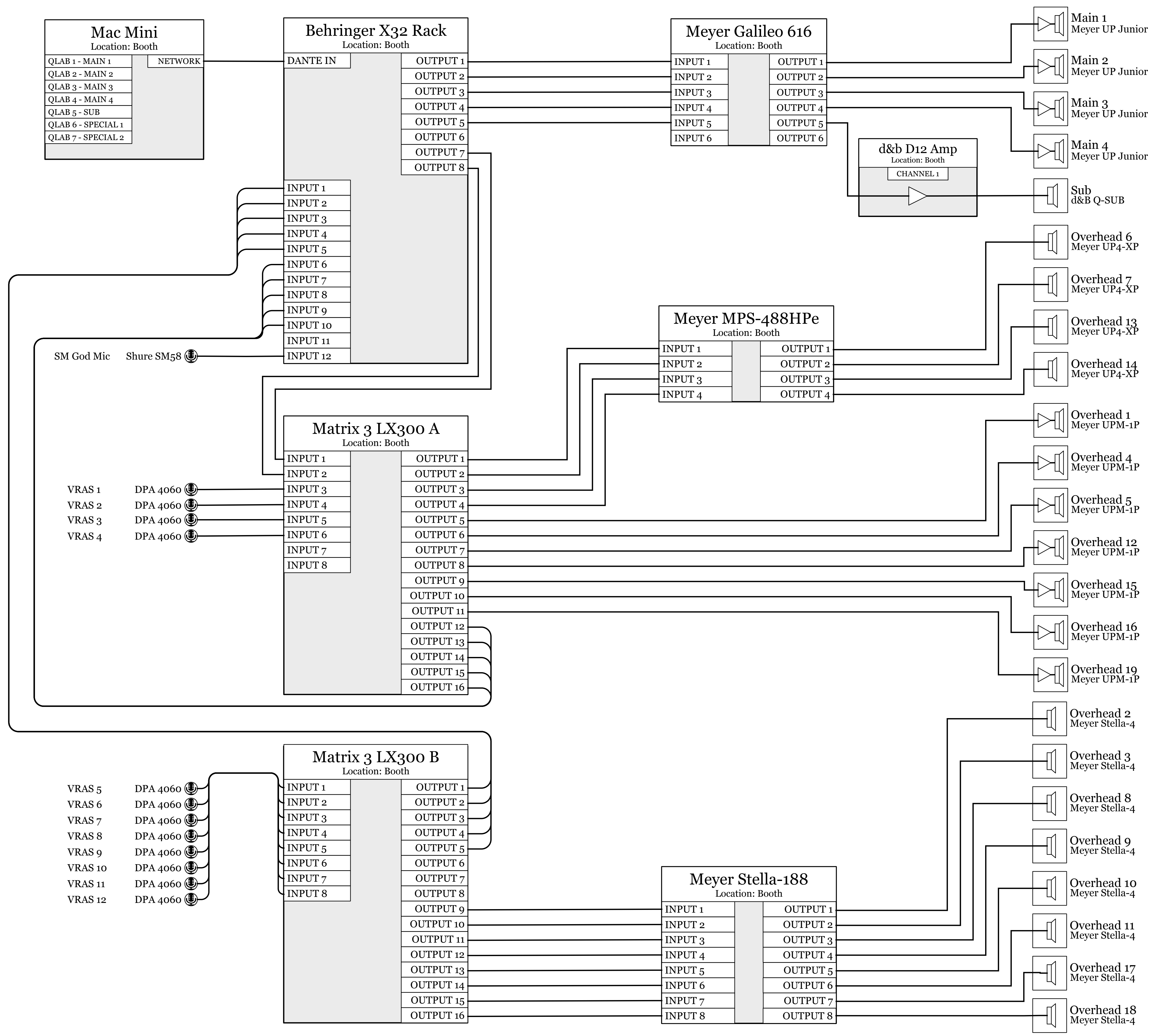

SOUND DESIGN BY:

**COSTANDINA J. DAROS**

**NOTES:**

1) INPUTS OF MATRIX 3 STILL TBD. WILL BE DETERMINED AFTER TESTING

**FINALS**

**THIS DRAFTING REPRESENTS CONCEPTS AND CONSTRUCTION SUGGESTIONS ONLY**

THE DESIGNER IS UNQUALIFIED TO DETERMINE THE STRUCTURAL OR ELECTRICAL APPROPRIATENESS OF THIS DESIGN AND ASSUMES NO RESPONSIBILITY FOR IMPROPER ENGINEERING, CONSTRUCTION, RIGGING, HANDLING, OR USE. FINISHED SYSTEM MUST COMPLY WITH ALL STATE AND LOCAL CODES.



**ROBERT COHEN THEATRE**

**THE EFFECT**

**DIRECTOR**  
CHLOE KING

**STAGE MANAGER**  
BRI WESTAD

**SCENIC DESIGNER:**  
JACQUELYNE EDWARDS

**COSTUME DESIGNER:**  
DENISE LARSSON

**LIGHTING DESIGNER:**  
NITA MENDOZA

**ASST. SOUND DESIGNER:**  
AERIK HARBERT

**SOUND SUPERVISOR:**  
JEFF POLUNAS

**SUBMITTALS:**

#	DATE:	DESCRIPTION:
1	02.12.2022	PRELIMINARY SUBMITTAL
2	02.27.2022	INTERMEDIATE
3	03.12.2022	FINALS
4		

**SYSTEM DIAGRAM**

SCALE: NTS PLATE: 4 OF 7  
DRAWN BY: C. DAROS

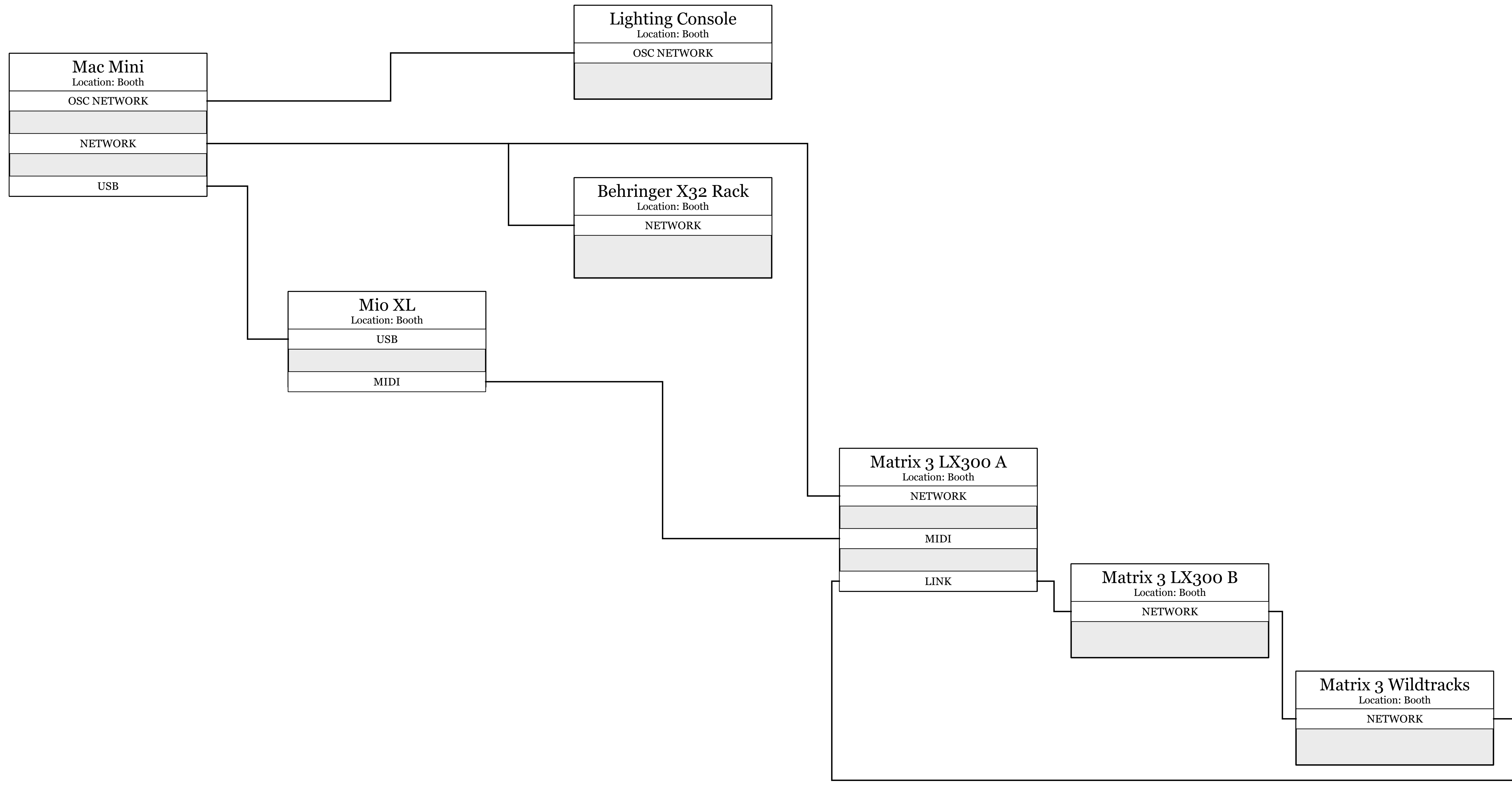

SOUND DESIGN BY:

COSTANDINA J. DAROS

NOTES:

1)

**FINALS**

**THIS DRAFTING REPRESENTS CONCEPTS AND CONSTRUCTION SUGGESTIONS ONLY**

THE DESIGNER IS UNQUALIFIED TO DETERMINE THE STRUCTURAL OR ELECTRICAL APPROPRIATENESS OF THIS DESIGN AND ASSUMES NO RESPONSIBILITY FOR IMPROPER ENGINEERING, CONSTRUCTION, RIGGING, HANDLING, OR USE. FINISHED SYSTEM MUST COMPLY WITH ALL STATE AND LOCAL CODES.



**ROBERT COHEN THEATRE**

**THE EFFECT**

**DIRECTOR**  
CHLOE KING

**STAGE MANAGER**  
BRI WESTAD

**SCENIC DESIGNER:**  
JACQUELYNE EDWARDS

**COSTUME DESIGNER:**  
DENISE LARSSON

**LIGHTING DESIGNER:**  
NITA MENDOZA

**ASST. SOUND DESIGNER:**  
AERIK HARBERT

**SOUND SUPERVISOR:**  
JEFF POLUNAS

**SUBMITTALS:**

#	DATE:	DESCRIPTION:
1	02.12.2022	PRELIMINARY SUBMITTAL
2	02.27.2022	INTERMEDIATE
3	03.12.2022	FINALS
4		

**DIGITAL CONNECTIONS**

SCALE:	NTS	PLATE:	
DRAWN BY:	C. DAROS		5 OF 7

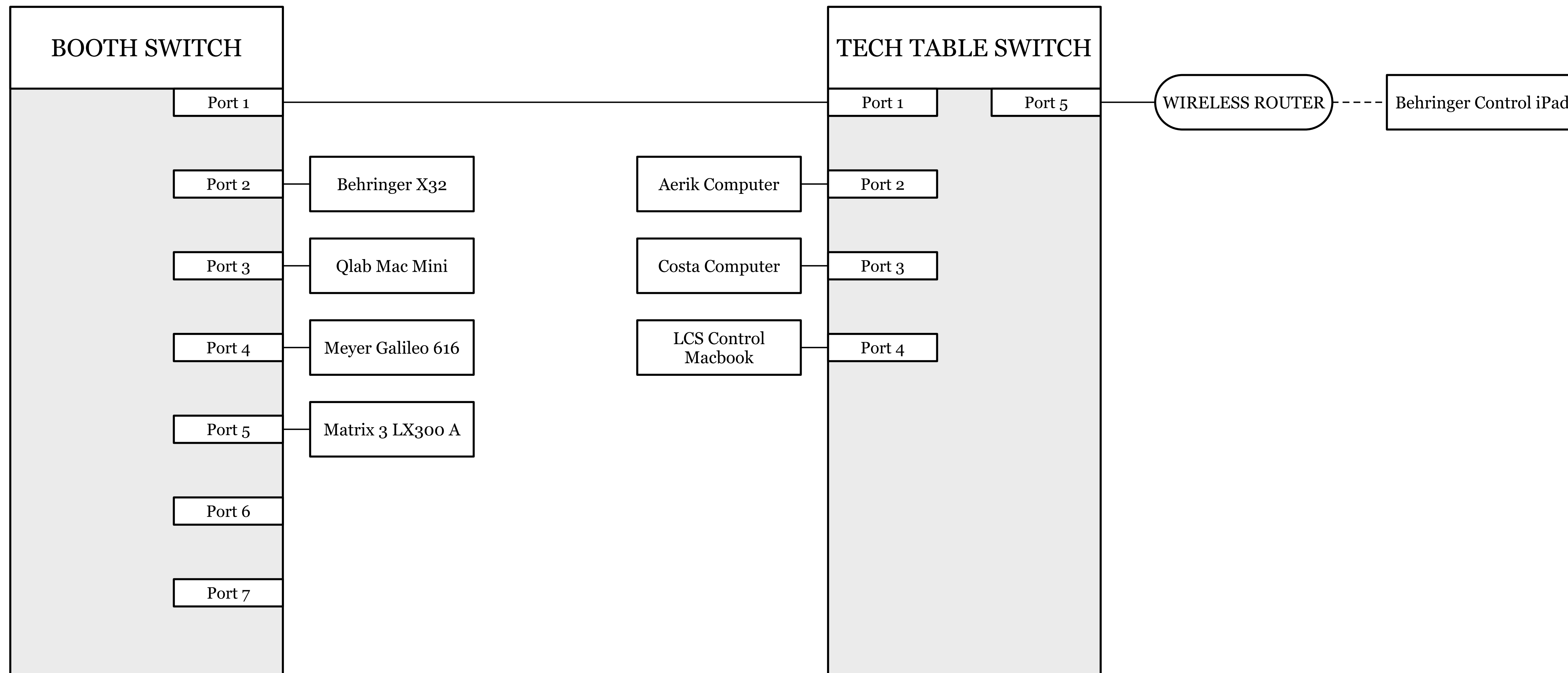

SOUND DESIGN BY:

COSTANDINA J. DAROS

NOTES:

1)

**FINALS**

**THIS DRAFTING REPRESENTS CONCEPTS AND CONSTRUCTION SUGGESTIONS ONLY**

THE DESIGNER IS UNQUALIFIED TO DETERMINE THE STRUCTURAL OR ELECTRICAL APPROPRIATENESS OF THIS DESIGN AND ASSUMES NO RESPONSIBILITY FOR IMPROPER ENGINEERING, CONSTRUCTION, RIGGING, HANDLING, OR USE. FINISHED SYSTEM MUST COMPLY WITH ALL STATE AND LOCAL CODES.



**ROBERT COHEN THEATRE**

**THE EFFECT**

**DIRECTOR**  
CHLOE KING

**STAGE MANAGER**  
BRI WESTAD

**SCENIC DESIGNER:**  
JACQUELYNE EDWARDS

**COSTUME DESIGNER:**  
DENISE LARSSON

**LIGHTING DESIGNER:**  
NITA MENDOZA

**ASST. SOUND DESIGNER:**  
AERIK HARBERT

**SOUND SUPERVISOR:**  
JEFF POLUNAS

**SUBMITTALS:**

#	DATE:	DESCRIPTION:
1	02.12.2022	PRELIMINARY SUBMITTAL
2	02.27.2022	INTERMEDIATE
3	03.12.2022	FINALS
4		

**NETWORK DIAGRAM**

SCALE: NTS PLATE: 6 OF 7  
DRAWN BY: C. DAROS



ALL MEASUREMENTS IN THE SPACE SHOULD BE TAKEN FROM THE INTERIOR OF THE HATCH NOT THE DASHED LINE

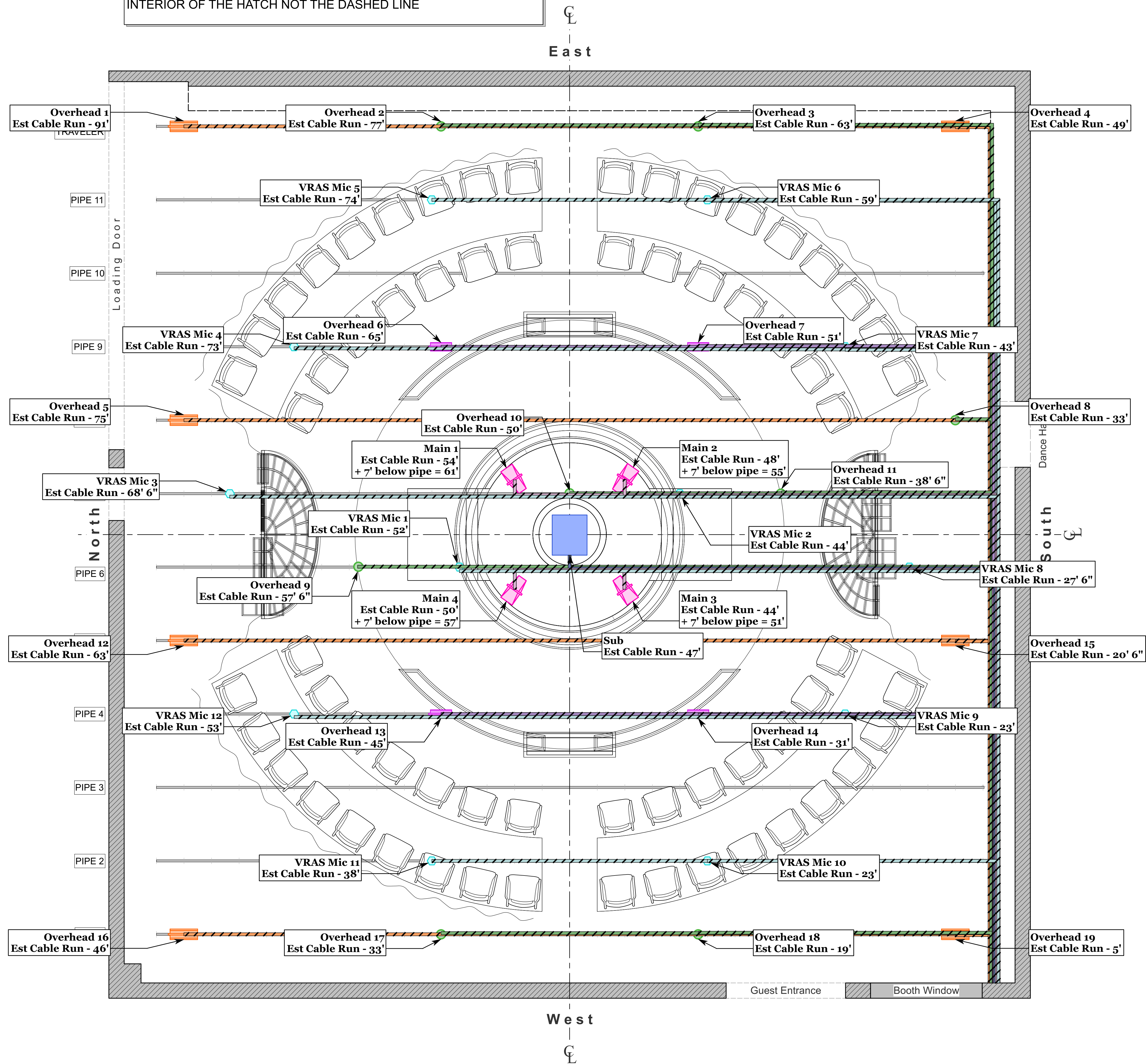

SOUND DESIGN BY:

COSTANDINA J. DAROS

NOTES:

1) ESTIMATES ONLY UP TO BOOTH WINDOW. DISTANCE TO RACK NOT INCLUDED

**FINALS**

THIS DRAFTING REPRESENTS CONCEPTS AND CONSTRUCTION SUGGESTIONS ONLY

THE DESIGNER IS UNQUALIFIED TO DETERMINE THE STRUCTURAL OR ELECTRICAL APPROPRIATENESS OF THIS DESIGN AND ASSUMES NO RESPONSIBILITY FOR IMPROPER ENGINEERING, CONSTRUCTION, RIGGING, HANDLING, OR USE. FINISHED SYSTEM MUST COMPLY WITH ALL STATE AND LOCAL CODES.



**ROBERT COHEN THEATRE**

**THE EFFECT**

**DIRECTOR**  
CHLOE KING

**STAGE MANAGER**  
BRI WESTAD

**SCENIC DESIGNER:**  
JACQUELYNE EDWARDS

**COSTUME DESIGNER:**  
DENISE LARSSON

**LIGHTING DESIGNER:**  
NITA MENDOZA

**ASST. SOUND DESIGNER:**  
AERIK HARBERT

**SOUND SUPERVISOR:**  
JEFF POLUNAS

**SUBMITTALS:**

#	DATE:	DESCRIPTION:
1	02.12.2022	PRELIMINARY SUBMITTAL
2	02.27.2022	INTERMEDIATE
3	03.12.2022	FINALS
4		

**CABLE PATHS**

SCALE: 3/8" = 1'-0"  
DRAWN BY: C. DAROS  
PLATE: 7 OF 7